

HORIZONTAL UNIT FOR HEAT METERS

Application

The Horizontal Unit for Heat Meters 80-PVA-H1 **te-sa** permits to install energy meters with standard length directly on the distribution manifold. The unit has nipple connections to the manifold equipped with O-ring sealing that allow to realize reliable junctions without additional assembly stress due to an excessive application of sealing materials. The interception ball valve has threaded housings for the insertion of the supply or return temperature probe.

The spacer for meters is made of High Tech polymer that allow pressure tests, and permits service in the cases where the meter is not immediately installed.

Made of high quality materials, it is ideally suited for applications on underfloor heating systems, radiator heating systems, fan coil units distribution systems, with condensing boilers, traditional boiler, or heating district distributions.

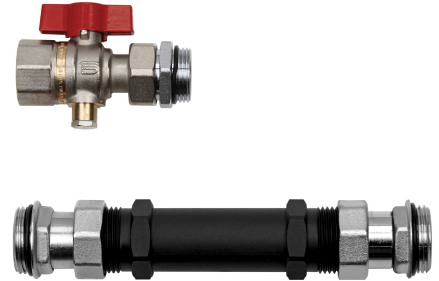

Technical data

- Manifold connections 1" size
- Interception ball valve nickel-plated with swivel nut flat seat, and probe housing threaded M10x1
- Brass components made of alloys UNI-EN 12164 CW614N and UNI-EN 12165 CW617N
- Spacer made of PA66 techno polymer, pressure and hot temperature resistant
- Suitable for Standard Energy Meters 3/4"x110 mm (80-PVA-H1-05) or 1"x130 mm (80-PVA-H1-06)
- Maximum Operating Pressure 10 bar
- Operating Temperature 0 ÷ 85°C
- Maximum Test Pressure 16 bar
- Maximum glycol percentage 30%

Dimensions

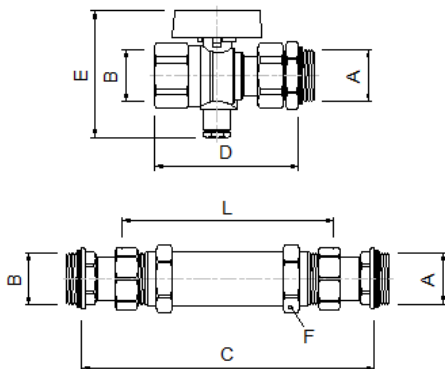

Art.	A	B	C	D	E	F	L
80-PVA-H1-05	1"M	3/4"	207	80.5	75	EX30	3/4" x 110
80-PVA-H1-06	1"M	1"	185	90	75	EX36	1" x 130