

COMPACT MAGNETIC DIRT SEPARATOR

Use

The compact dirt separator Art. 60DMC051 **te-sa** allows to remove the impurities of ferrous origin, sands, shavings produced in the deburring of synthetic pipes, agglomerates of algae or floccules, that are contained and carried by the water circulating in conditioning systems. The elimination of these particles, maintains high the efficiency of the system, and reduces the probability of malfunctioning.

Its use allows to lengthen the useful life of the boilers avoiding problems of clogging in the exchangers and in the circulators, and also galvanic corrosion phenomena.

Its compact dimensions have been developed to allow the installation of wall-mounted boilers, allowing easy maintenance operations without special tools.

The dirt separator is mounted on the system return pipe in order to protect the boiler and its components. Its installation is strongly recommended in the case of existing domestic systems, where it is made a replacing of the boiler in presence of ferrous distribution pipes, cast iron or steel radiators, radiant floor systems with pipes without oxygen barrier.



Characteristics

The magnetic dirt separator **te-sa** despite being particularly compact thanks to its morphology, it allows to obtain a high level of separation of the impurities carried by the system waters.

The incoming water flow meets the spiral turbulator which generating a whirling motion that allows the separation of the suspended particles, which by agglomerating, they precipitate on the bottom of the lower body. The ferromagnetic particles are attracted by the three magnets of which the dirt separator is equipped and remain attached to the lower part of it.

A mesh filter blocks residual impurities before the fluid flows to the discharge chamber.

With a periodic cleaning carried out with the system turned off but also under pressure, after having unhooked the magnet holder shell from the body, it is possible wash the impurities, ferrous or otherwise deposited in the lower part of the dirt separator.

An extraordinary cleaning that also includes the mesh filter and the turbulator, it can easily be carried out by disassembling the lower body, after intercepting the water flow, and discharge of the water contained in the dirt separator.

Technical Data

- For use with hot and cold water in conditioning distribution systems
- Maximum operating pressure 10 bar
- Range of operating temperature -5÷110°C
- Maximum percentage of glycol 50%
- Forged components made of brass alloy UNI-EN12165:16 CW617N
- Casted components made of brass alloy UNI-EN 1982:17 CB753S
- Machined from rod components made of brass alloy UNI-EN12164:16 CW614N
- Seal O-ring made of EPDM
- Male connections flat seat G3/4" - DN20
- Suggested maximum flow 1.3 m³/h
- Flow capacity KV = 9 (with clean filter)
- Orientable drain valve with hose connection 3/4" completes of cap
- Stainless Steel filter AISI 304 with mesh 800 µm
- Spiral turbulator made of Stainless Steel AISI 304
- Three Neodymium magnets with Magnetic Induction Field B equal to 1.2 Tesla each
- Possibility of removing deposits even with system in function
- Easily demountable to cleaning the internal components
- Possibility of assembling on boilers with inline connection or with vertical connection
- Completely "Made in Italy" product
- 60DMC051: version complete with impurity drain cock, flat seat unions for wall mounted boiler connection and to the system
- 60DMC052B: with body painted white RAL9010

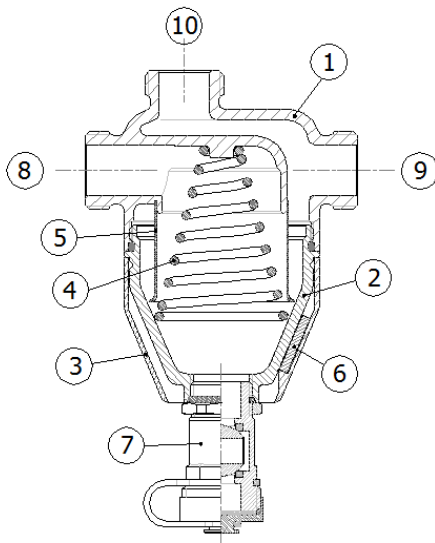

- 1 Upper Body
- 2 Lower Body
- 3 Magnets holder shell
- 4 Spiral turbulator
- 5 Stainless Steel filter
- 6 Neodymium magnets
- 7 Drain valve
- 8 Water Inlet
- 9 Inline water outlet
- 10 Vertical water outlet

Dimensions

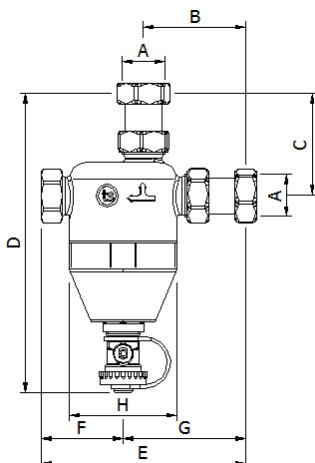

Art.	A	B	C	D	E	F	G	H
60DMC051	3/4"	63	63	184	125	50	75	66