

ENDPIECE WITH CLAMPING NUT AND ACCESSORIES FOR MANIFOLDS

Application

The endpiece for manifolds includes automatic air vent valve and fill&drain valve. It can be assembled on brass and stainless steel manifolds 1" size and allows with its accessories to fill or drain water in the system and remove the air bubbles transported by the water flow. The installation of an endpiece for each manifold is recommended. Made of brass chrome plated has functionality and resistance to the corrosions.



Assembly

To assembly the endpiece it is necessary as first step screw the 1" male thread to the manifold until reach a vertical position for the two accessories air vent and fill&drain valve. The second step is to screw the clamping nut of the endpiece against the manifold, and by using a wrench, apply a torque force that permits to press the O-ring on the manifold head.

The automatic air vent valve should be positioned on top, and the fill&drain valve need to be screwed in the below thread of the endpiece.

Technical data

- For use with hot and cold water in conditioning systems
- Threaded connection 1" male. Accessories connections 1/2" female
- Maximum operating pressure 10 bar
- Range of operating temperature 0 ÷ 95°C
- Forged components made of brass alloy UNI-EN 12165 CW617N
- Directly machined from rod components made of brass alloy UNI-EN 12164 CW614N
- O-ring made of EPDM
- Automatic air vent valve 1/2" connection with O-ring seal
- Orientable fill&drain valve 1/2" connection with O-ring seal, and hose connection 3/4"

Dimensions

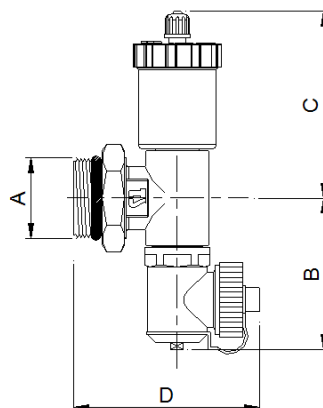

Art.	A	B	C	D
254CD-06	1"	58	82	73